



Customer information packet

CFSWDM3546T-E-G

1HP, 1770RPM, 3PH, 60HZ, 143TC, 3522M, TENV, F1

Class - None

Division - Not Applicable

Specifications

Enclosure	TENV
Frame	143TC
Frame Material	Stainless Steel
Frequency	60.00 Hz
Haz Area Class and Group	None
Haz Area Division	Not Applicable
Motor Letter Type	Three Phase
Output @ Frequency	1.000 HP @ 60 HZ
Phase	3
Synchronous Speed @ Frequency	1800 RPM @ 60 HZ
Voltage @ Frequency	460.0 V @ 60 HZ 230.0 V @ 60 HZ
Agency Approvals	CURUSEEV NEMA PREMIUM WEEE
Ambient Temperature	40 °C
Auxiliary Box	NO AUXILLARY BOX
Auxiliary Box Lead Termination	None
Base Indicator	Rigid
Bearing Grease Type	Polyrex EM (-20F +300F)
Blower	None
Current @ Voltage	3.300 A @ 208.0 V 3.340 A @ 230.0 V 1.670 A @ 460.0 V
Design Code	B
Drip Cover	No Drip Cover
Duty Rating	CONT
Efficiency @ 100% Load	85.5 %
Electrically Isolated Bearing	Not Electrically Isolated
Feedback Device	NO FEEDBACK
Front Shaft Indicator	None
Heater Indicator	No Heater

Part detail

Revision	-
Type	AC
Mech. spec.	35E6049
Base	
Status	PRD/A
Elec. spec.	35WGG184
Layout	35LYE6049
Eff. date	08-14-2023
CD Diagram	CD0005
Poles	04
Leads	9#18
Proprietary	False
Created date	07-06-2023

High Voltage Full Load Amps	1.7 a
Insulation Class	H
Inverter Code	Inverter Ready
KVA Code	N
Lifting Lugs	No Lifting Lugs
Locked Bearing Indicator	Locked Bearing
Max Speed	2700 rpm
Motor Finish	UNPAINTED
Motor Lead Quantity/Wire Size	9 @ 18 AWG
Motor Lead Termination	Flying Leads
Motor Standards	NEMA
Motor Type	3522M
Mounting Arrangement	F1
Number of Poles	4
Overall Length	12.84 IN
Power Factor	66
Product Family	WD All SS Encapsulated
Pulley End Bearing Type	Sealed Bearing
Pulley Face Code	C-Face
Pulley Shaft Indicator	Standard
Rodent Screen	None
RoHS Status	ROHS COMPLIANT
Service Factor	1.15
Shaft Diameter	0.875 IN
Shaft Ground Indicator	Shaft Grounding
Shaft Rotation	Reversible
Shaft Slinger Indicator	No Slinger
Speed	1770 rpm
Speed Code	Single Speed
Starting Method	Direct on line
Thermal Device - Bearing	None
Thermal Device - Winding	None
Vibration Sensor Indicator	No Vibration Sensor
Winding Thermal 1	None

Winding Thermal 2

None

Nameplate

NP4427AAA01A									
CAT #	CFSWDM3546T-E-G				LBS				
SPEC	35E6049G184G1				ENCL	TENV			
SER #					CC	010A	IP	69	
HP	1		MAG CUR	2.5/1.25					
VOLTS	230/460				NEMA NOM. EFF	85.5			
AMPS	3.34/1.67				PF	66			
RATING	40C AMB-CONT								
RPM	1770				MAX RPM	2700			
FRAME	143TC	HZ	60	CODE	N	CLASS	H		
SER.F.	1.15	SF AMP	3.5/1.75		PH	3	DES	B	
DE	6205		ODE	6205					
LUBRICATION	POLYREX EM								
ID LOGO	INVERTER TYPE	VPWM	CHP	60	TO	90	1.5:1		
ID LOGO	WK2	0.159	CT	3	TO	60	20:1		
ID LOGO	SL HZ	1	VT	3	TO	60	20:1		
					QR				
YR									

AC Induction Motor Performance Data

Record # 75065

Typical performance - not guaranteed values

Winding: 35WGW045-R003		Type: 3522M		Enclosure: TENV	
Nameplate Data			460 V, 60 Hz: High Voltage Connection		
Rated Output (HP)	1	Full Load Torque	3.01 LB-FT		
Volts	230/460	Start Configuration	direct on line		
Full Load Amps	3/1.5	Breakdown Torque	13.4 LB-FT		
R.P.M.	1760	Pull-up Torque	7.77 LB-FT		
Hz	60 Phase	3	Locked-rotor Torque	9.5 LB-FT	
NEMA Design Code	B	KVA Code	M	Starting Current	13.5 A
Service Factor (S.F.)	1.15	No-load Current	1.02 A		
NEMA Nom. Eff.	85.5	Power Factor	74	Line-line Res. @ 25°C	14.4 Ω
Rating - Duty	40C AMB-CONT		Temp. Rise @ Rated Load	78°C	
S.F. Amps			Temp. Rise @ S.F. Load	91°C	
			Locked-rotor Power Factor	54	
			Rotor inertia	0.13 LB-FT ²	

Load Characteristics 460 V, 60 Hz, 1 HP

% of Rated Load	25	50	75	100	125	150	S.F.
Power Factor	31	49	62	71	77	81	75
Efficiency	73.4	82.2	85.1	85.6	85	83.9	85.2
Speed	1790	1780	1771	1760	1749	1736	1753
Line amperes	1.06	1.19	1.35	1.55	1.79	2.07	1.69

ABB Motors and Mechanical Inc.

WINDING # 35WGW045

Typical performance - not guaranteed values.

1 HP 3 PH 60 HZ 1760 RPM 460 V 3522M

TORQUES (LB-FT): PO=13.4 PU=7.77 LR=9.5 LRA=13.5

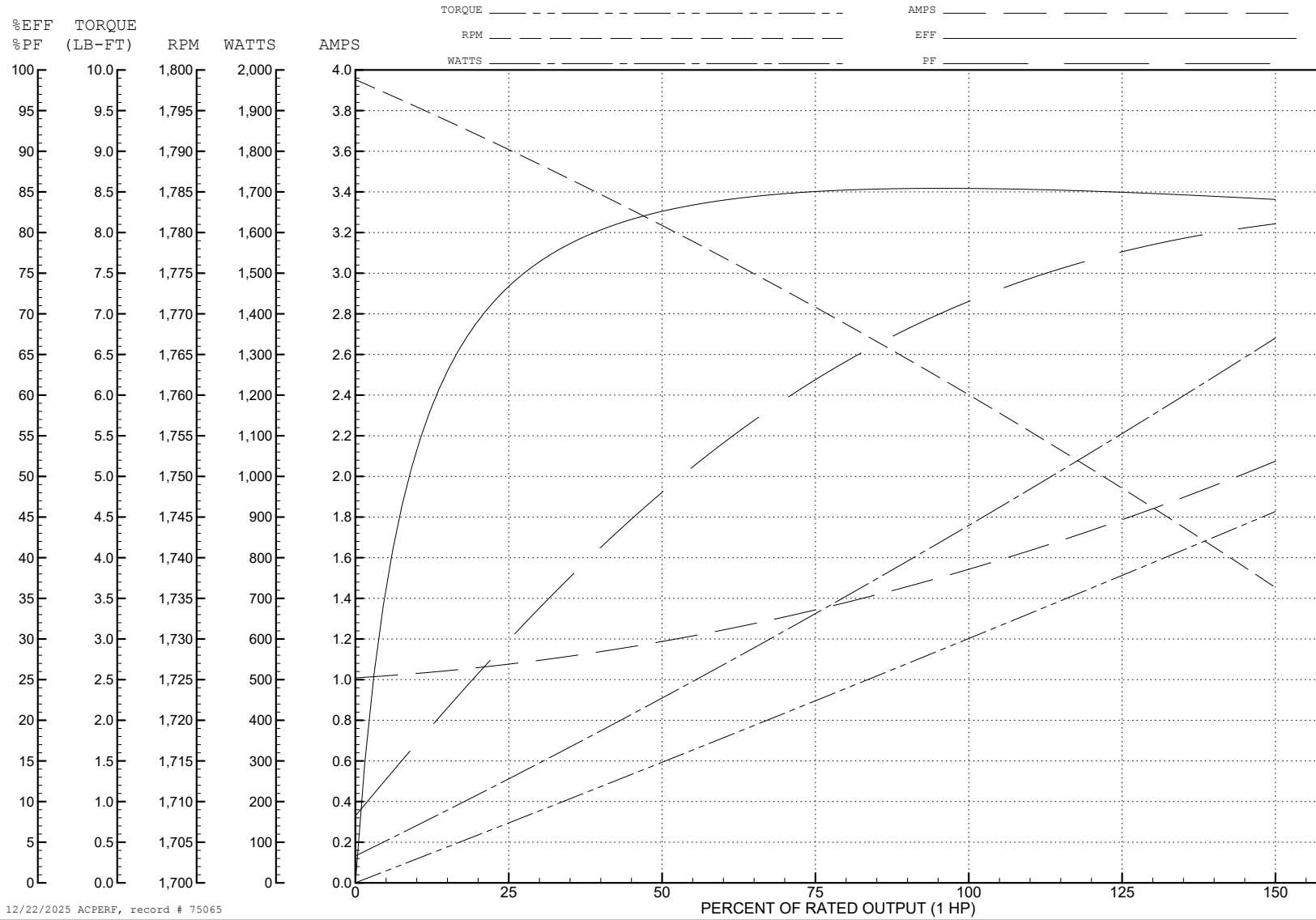

12/22/2025 ACPERF, record # 75065

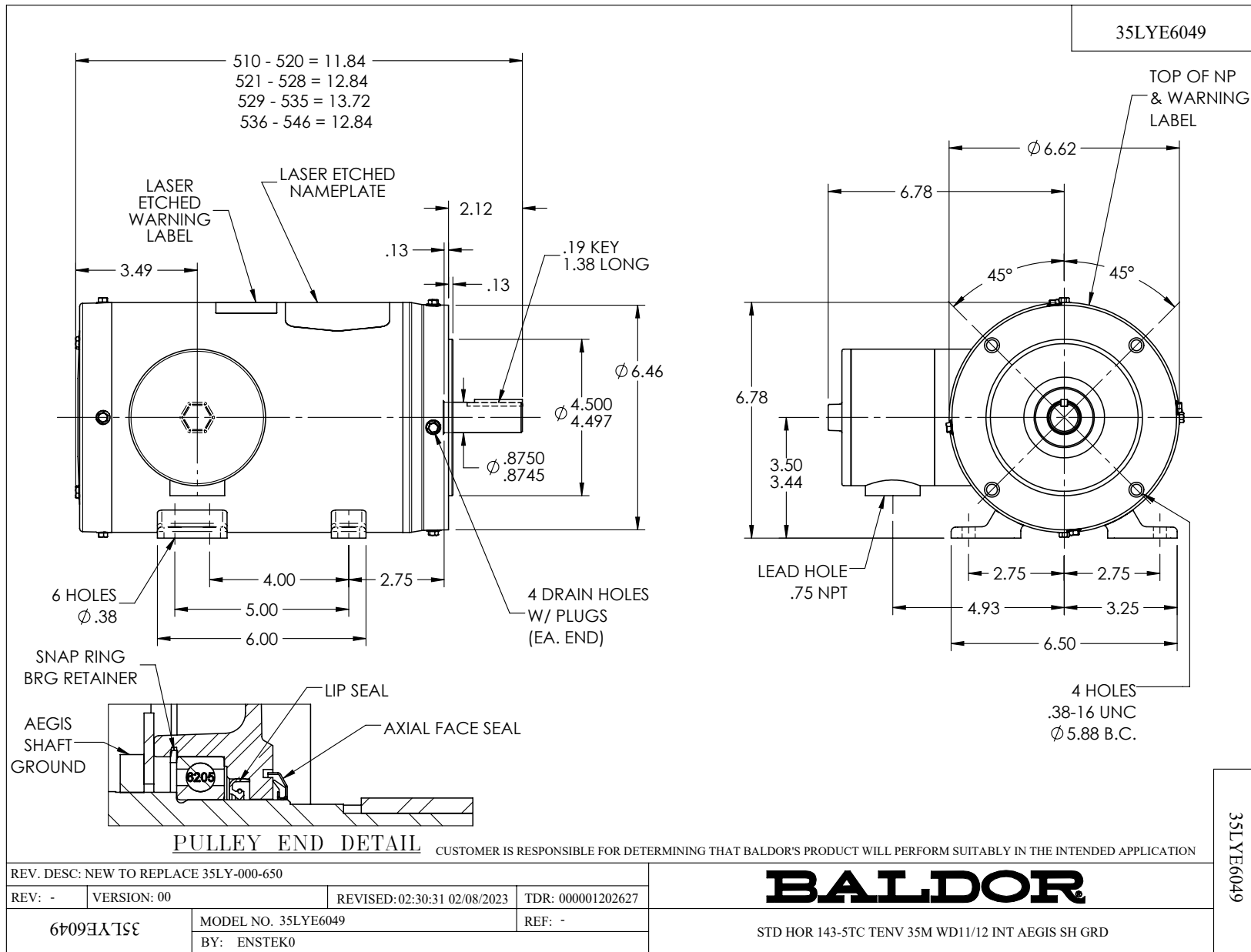

CD0005

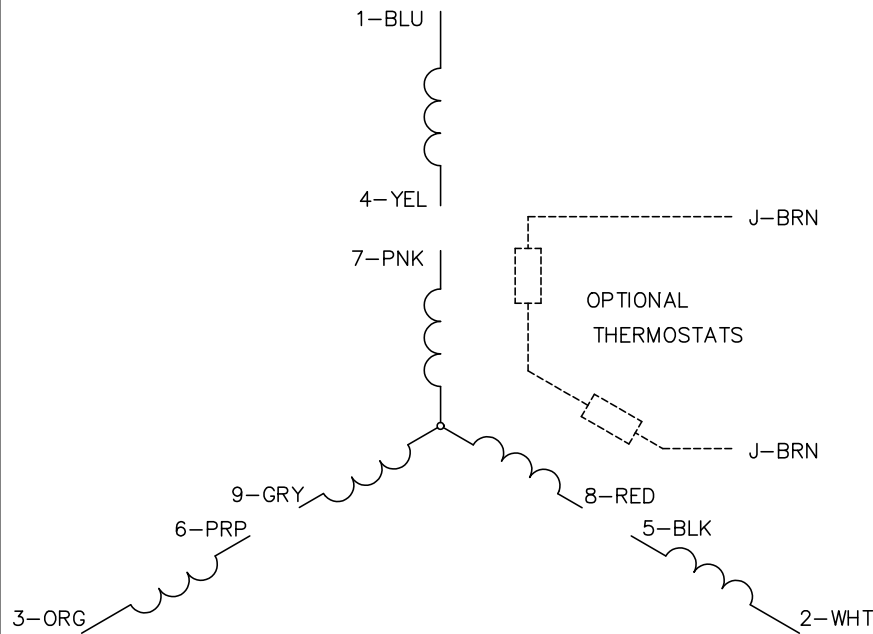

LOW VOLTAGE
(2Y)

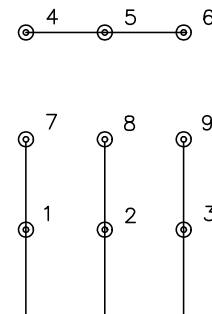

LINE

HIGH VOLTAGE
(1Y)



LINE

NOTES:

1. INTERCHANGE ANY TWO LINE LEADS TO REVERSE ROTATION.
2. OPTIONAL THERMOSTATS ARE PROVIDED WHEN SPECIFIED.
3. ACTUAL NUMBER OF INTERNAL PARALLEL CIRCUITS MAY BE A MULTIPLE OF THOSE SHOWN ABOVE.
4. LEAD COLORS ARE OPTIONAL. LEADS MUST ALWAYS BE NUMBERED AS SHOWN.

REV. DESC: REVISE TO SHOW OPTIONAL COLORS			
REV. LTR: E	BY: JLP	REVISED: 01/19/99 10:15	TDR: 0171435
S00000		FILE: AAA00005140	MDL: -
		MTL: -	

BALDOR ELECTRIC Co.

3PH, DV, 9 LEADS

CD0005